



Winston Series CPC

Solar Collector

Installation Instructions

Solargenix Energy, LLC. • Headquarters: 2101-115 Westinghouse Blvd. • Raleigh, NC 27604
Phone: 919-871-0423 • Fax: 919-871-0702 • E-Mail: email@solargenix.com

Introduction

The installation of this solar collector should only be performed by personnel qualified in plumbing and roofing. The installation should comply with local building codes, permits and OSHA requirements. The collector installation can be retrofitted to existing buildings or integrated into new construction projects.

Theory of Operation

A solar collector is simply a heat exchanger designed to convert the sun's radiant light energy into thermal energy to be stored for later use. This collector uses non-imaging optics and parabolic concentration technology to heat the fluid media passing through the selectively coated tubing manifold. The fluid media is circulated, via a pump, through the collector and into a storage tank located within the home/building.

Collector Orientation

The performance of solar collector in the Northern Hemisphere is optimized when the collector is mounted facing true south (Figure 1). Performance, however, suffers very little when the collector is oriented no more than 45° East or West of True South. The collector should be un-shaded by any permanent obstacle between 9:00 a.m. and 3:00 p.m. on any day of the year.

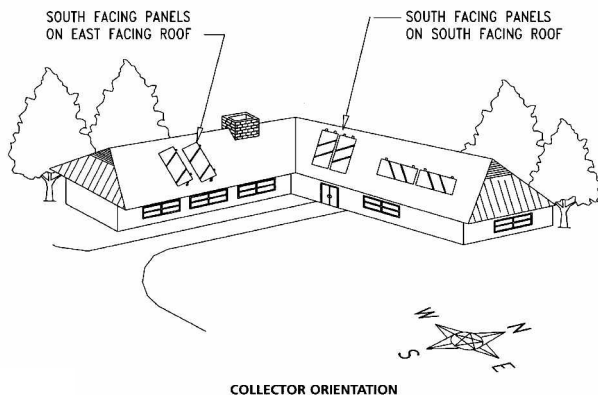

Figure 1

Collector Tilt

Optimal annual efficiency is achieved by tilting the solar collector at an angle that equals your latitude plus an additional 10°. This tilt angle favors the lower winter sun when collector performance is at its lowest and minimizes overheating during the hottest summer months.

The solar collectors in a two collector staggered mount installation must be spaced far enough apart to prevent winter shading. Table 1 and Figure 2 show the correct spacing between collectors to prevent shading on December 21, when the sun is at its lowest angle.

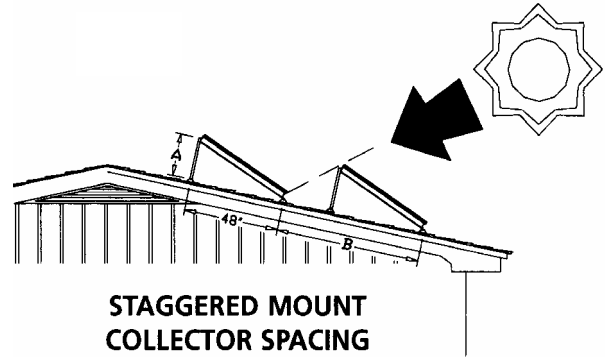

Figure 2

Basic Mounting Procedures

The solar collector(s) can be mounted in either a vertical or horizontal orientation on the roof (Figure 1). Freeze protection is strongly recommended; therefore, the collector should always be mounted in a vertical orientation. It is still important to slope the collector just slightly to allow for complete drainage during off mode. The required slope is at least 1/4" vertical rise per foot of horizontal run.

To ensure proper water drainage from the glazing, the collector must maintain a minimum angle from horizontal of at least 10°. Never mount the collector directly or parallel to a flat roof surface. Use the universal tilt mount kit and 1" aluminum square tube to rack the collector to the proper angle.

The collector should be mounted as close to the storage tank as possible to minimize heat loss in the piping runs. If the home has limited attic access, mounting the collectors nearer the roof peak provides for additional attic workspace. The solar collector should be mounted on the roof in accordance with these general principles:

The most important structural consideration is to securely anchor the solar collector and the mounting hardware to the structural members of the roof with stainless steel hanger or lag bolts.

LATITUDE		25°N		30°N		35°N		40°N		45°N		50°N	
COLLECTOR TILT		35°		40°		45°		50°		55°		60°	
Figure 2 Dimensions		A	B	A	B	A	B	A	B	A	B	A	B
ROOF PITCH	FLAT	29"	96"	33"	113"	37"	145"	41"	145"	44"	145"	48"	145"
	5° 1/12	25"	83"	29"	93"	33"	113"	37"	132"	41"	133"	44"	141"
	9° 2/12	22"	74"	26"	82"	30"	77"	34"	110"	38"	115"	41"	118"
	14° 3/12	17"	66"	22"	72"	26"	82"	30"	92"	34"	95"	38"	98"
	18° 4/12	14"	61"	18"	66"	22"	74"	26"	82"	30"	85"	34"	87"
	23° 5/12	10"	58"	14"	60"	18"	66"	22"	72"	26"	74"	30"	77"
	27° 6/12	7"	58"	11"	58"	15"	61"	19"	66"	23"	68"	27"	70"
	30° 7/12	4"	58"	8"	58"	13"	58"	17"	62"	21"	65"	25"	66"
	34° 8/12	0"	58"	5"	58"	9"	58"	13"	58"	17"	60"	22"	62"
	37° 9/12	0"	58"	3"	58"	7"	58"	11"	58"	15"	58"	19"	58"
	40° 10/12	0"	58"	0"	58"	4"	58"	8"	58"	13"	58"	17"	58"
	43° 11/12	0"	58"	0"	58"	2"	58"	6"	58"	10"	58"	14"	58"
45° 12/12	0"	58"	0"	58"	0"	58"	4"	58"	8"	58"	13"	58"	

DIMENSIONS A AND B ARE DEFINED IN FIGURE 2. AND ARE DESIGNATED IN INCHES

Table 3

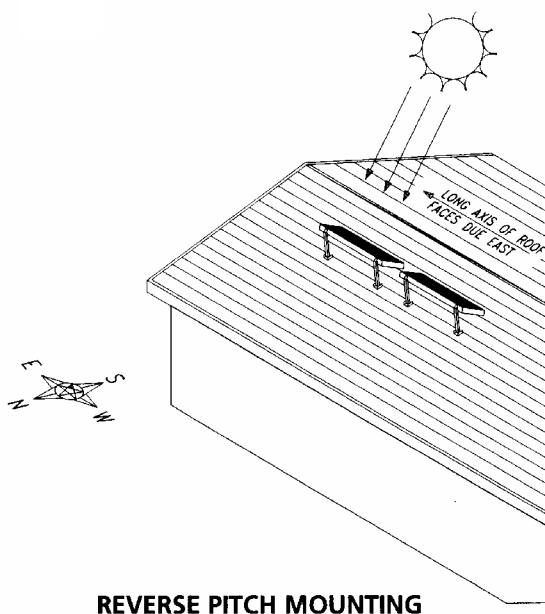

REVERSE PITCH MOUNTING

Figure 5

The collector must be raised from the roof surface to allow for rainwater and debris to pass under the collector and for proper ventilation of the roofing material. There should be at least 1 1/2" of clearance between the roof surface and the bottom of the solar collector.

In selecting mounting hardware and fasteners it is extremely important to avoid galvanic corrosion resulting from the direct contact of incompatible metals. Use the stainless steel "Universal Mount" hardware and stainless steel lag or hanger bolts, lock washers and round washers is recommended. In climates subject to severe winters or high humidity, the use of galvanized fasteners is prohibited.

Preserving the integrity of the roof membrane is the most important roofing consideration. Ensure that all roof penetrations, required to plumb and mount the solar collector, are properly flashed and sealed in accordance with standard roofing practices. Tremco's "POLYroof" is the recommended elastomer for sealing roof penetrations. Henry Co. 204, 208 or 209 roof mastic or Dow Corning Glazing Sealant also are acceptable sealants.

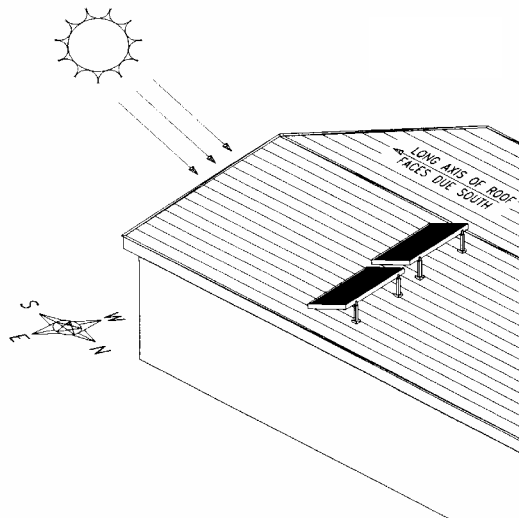

SIDE PITCH MOUNTING

Figure 6

If the region is subject to high wind or hurricane conditions, additional steps may be required to secure the collector and mounting hardware to the structural members. In certain areas of the country, local building codes may require collector wind load testing or prescribe specific mounting procedures. Consult your local building department.

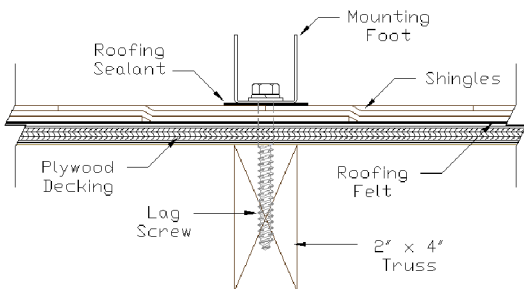

Figure 7

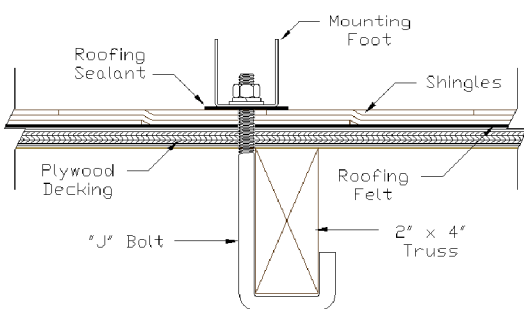

Figure 8

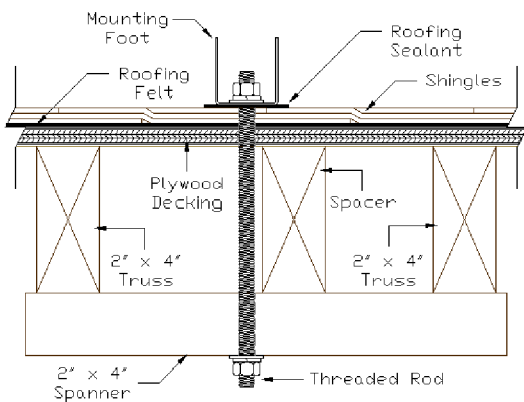
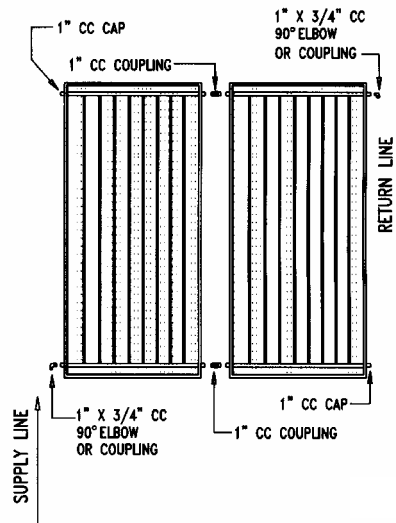

Figure 9

Collector Plumbing

This installation requires the use of all copper and brass fittings in the collector loop plumbing. Couplings rather than unions should be used to join the collectors to avoid leaks and fluid loss. Use only lead-free solder. Use of 50/50 lead solder is expressly prohibited. Use of galvanized steel, CPVC, PVC, or any other type of plastic pipe is prohibited. The minimum size for the "To" and "From" collector piping is 5/8" OD copper.

Piping in new solar installations can be covered with dirt, grease, solder flux or other impurities that over time affect the quality of the distilled water or propylene glycol heat transfer fluid (HTF). A thorough cleaning is required before charging the system.



COLLECTOR PLUMBING - VERTICAL MOUNT
Figure 10

Collectors are designed to be installed in the vertical position (Figure 10). All vertical piping between the storage tank and the collector shall be supported at each story or at maximum intervals of ten (10) feet. Copper plumbers tape or tube strap is required. The pipe insulation may not be compressed or crimped by the strapping material.

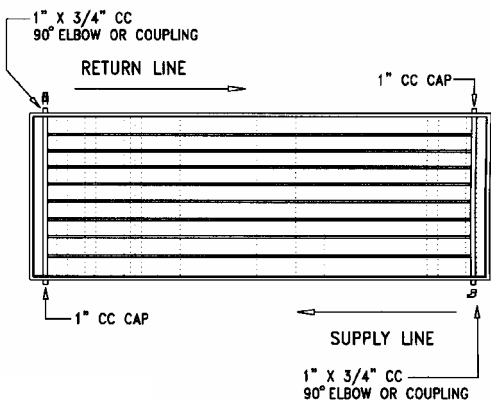

COLLECTOR PLUMBING - HORIZONTAL MOUNT
Figure 11

It is not recommended that collectors be mounted with the parallel flow tubes in the horizontal position (Figure 11). In the event this is the only option, the collectors must slope downward toward the collector inlet by no less than 1/4" per foot.

The "To" and "From" Collector plumbing lines should also slope $\frac{1}{4}$ " per foot from the collectors back to the tank.

The installation of all horizontal and vertical piping may not reduce the performance or rating of any structural member or fire rated assembly. Adhere to all applicable local codes and ordinances.

This solar collector is leak tested at the factory. Once the collector has been installed as part of a domestic solar water heating system, the system should be filled, pressurized and checked for leaks. Repairs should be corrected and the system retested prior to insulation installation.

Pipe Flashings:

Pipe flashings are used to transition through the roof membrane and into the attic space for subsequent connection to the interconnect plumbing. All roof penetrations are to be sealed in accordance with standard roofing practices. Make roof penetrations between trusses to allow for thermal expansion and slight flexing of the pipe from wind buffering.

Standard plumbing roof vent stack flashings can be used, however, the rubber or plastic boot must be protected from the sun. Figure 12 details an all copper flashing which uses a "coolie" cap soldered to the interconnect plumbing. This connection should be made prior to insertion through the flashing base.

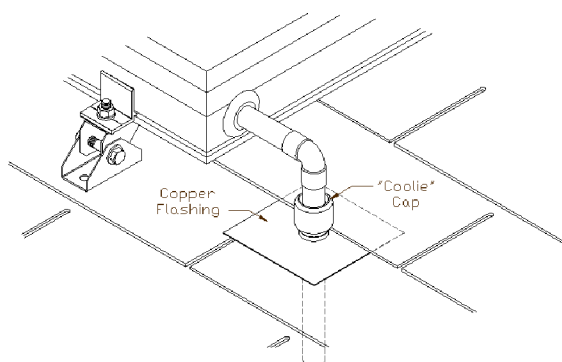

Figure 12

Collector Loop Pipe Insulation

The collector loop cold supply and hot return lines must be well insulated with a high quality flexible closed cell insulation to minimize heat loss. The wall thickness of the pipe insulation should not be less than $\frac{3}{4}$ ". A 1" wall thickness is required in all areas prone to annual hard freeze conditions. When it comes to pipe insulation the rule is simple: thicker is better. The specified insulation material is Rubatex Insul-Tube 180 or equal.

To the extent possible, slide the insulation material over the pipe without cutting or taping. All butt joints must be sealed with contact adhesive. The use of rigid polyethylene pipe insulation is prohibited. The temperatures generated by your collector in the summer months or under stagnation conditions can melt this type of material.

Any above ground exterior pipe insulation is subject to ultra-violet (UV) degradation and must be wrapped with foil tape or painted with two coats of high quality water-based acrylic resin coating as supplied by the insulation manufacturer. Rubatex UV Protective Coating or its equal is the required coating material.

Collector Sensor Placement (When Differential Controller is used)

The collector sensor must be located on the hot water return line as close to the collector as possible. Sensors are typically accurate to $\pm 1/2^\circ\text{F}$ if properly installed and weatherized. To maximize sensor accuracy, attach the flanged portion of the sensor to the solar collector header pipe, as close as possible to the collector outlet, with a stainless steel hose clamp. Wire nuts used to connect the sensor and low voltage wiring shall be all plastic, sealed with silicone and thoroughly wrapped in electrician's tape.

The sensor "bundle" must be placed under the rubber pipe insulation covering the collector header. Thoroughly wrap and weatherize the insulation with electrician's tape or insulation tape as provided by the manufacturer (Rubatex Insul-Tape or equal). See Figure 13 for collector sensor installation detail.

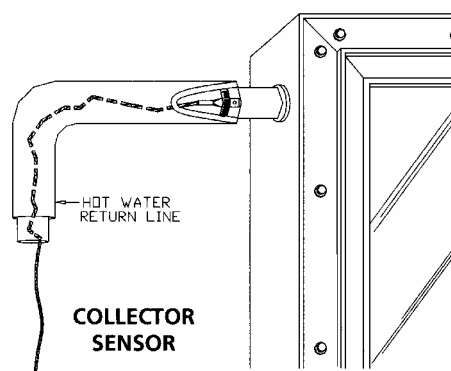

Figure 13

Low Voltage Wiring:

Low voltage wiring is used to connect the collector sensor to the controller and should be a minimum 18 AWG. The wiring should be stranded bare or tinned copper, two-conductor type.

The wiring should be PVC insulated, with a PVC UV rated gray jacket suitable for exterior use. Use Eastman Wire & Cable No. 5704, Belden Wire and Cable No. 8461 or equivalent.

This completes the system installation procedure.

Collector Maintenance:

Collectors operate best when the glass is clean and unobstructed. If they become dirty wash them with mild soapy water and rinse. Remove any branches or leaves that do not naturally fall off or are blown away by the wind. Collectors installed at the proper angle anywhere in the continental United States should not have either of these problems. Dust and dirt build can be a problem in dry desert climates where there is little rain to wash the glass.

SPECIFICATIONS

Overall dimensions:

A = 3.40"

B = 41.95"

C = 82.45"

Perimeter Area: 24.02 ft²

Aperture Area: 22.32 ft²

Dry Weight: 69 lbs

Cover Plate:

Material: Low-Iron Float Glass

Thickness: 3.3mm

Dimensions: 41.38" x 82.06"

Cover Plate Gasket: Silicone sealant bonded to framewall and batten

Back Plate: Type 3105-H154 Stucco Embossed Aluminum
0.019" Thick

Framewall & Battens: Type 6063-T6 Aluminum Alloy Extrusions

Reflectors: Type Polished Aluminum
0.020" Thick

Absorber Manifold:

Material: Type M Hard Copper

Headers: 1" Nominal (1.125" OD)

Risers: ¾" Nominal (0.875" OD)

Fluid Cap: 2.45 Gals

Coating: Black Crystal © or SOLEC
Semi-selective Coating

Absorptivity: 0.94

Emmissivity: 0.12

Weight: 30 lbs

Insulation:

Material: Polyurethane Foam

K-Factor: 0.024 w/m°C

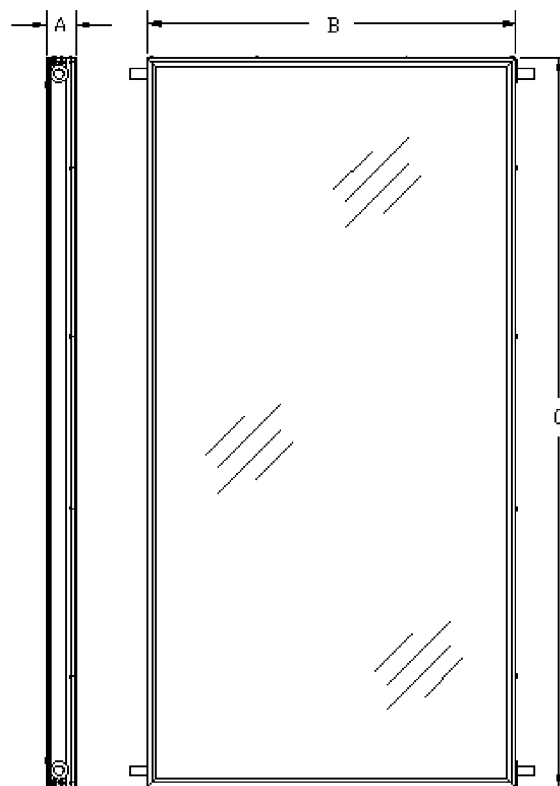

Figure 14

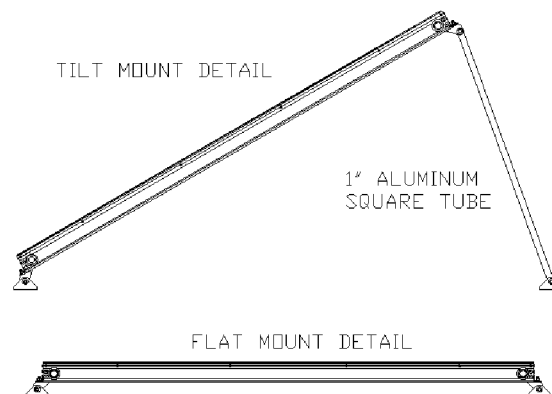

Figure 15

This product manufactured by:

Solargenix Energy, LLC.
3622 South Morgan Street
Chicago, Illinois 60609
Phone: 773-847-8333
Fax: 773-847-8555
E-Mail : email@solargenix.com